

มาตรฐานผลิตภัณฑ์อุตสาหกรรม

THAI INDUSTRIAL STANDARD

มอก. 1806 เล่ม 2-2542

ISO 8669-2 : 1996

ถุงเก็บปัสสาวะ

เล่ม 2 คุณลักษณะที่ต้องการและวิธีทดสอบ

URINE COLLECTION BAGS -

PART 2 : REQUIREMENTS AND TEST METHODS

สำนักงานมาตรฐานผลิตภัณฑ์อุตสาหกรรม

กระทรวงอุตสาหกรรม

ICS 11.080

ISBN 974-608-249-3

มาตรฐานผลิตภัณฑ์อุตสาหกรรม

ถุงเก็บปัสสาวะ

เล่ม 2 คุณลักษณะที่ต้องการและวิธีทดสอบ

มอก. 1806 เล่ม 2—2542

สำนักงานมาตรฐานผลิตภัณฑ์อุตสาหกรรม

กระทรวงอุตสาหกรรม ถนนพระรามที่ 6 กรุงเทพฯ 10400

โทรศัพท์ 0 2202 3300

ประกาศในราชกิจจานุเบกษา ฉบับประกาศทั่วไป เล่ม 118 ตอนที่ 94ง

วันที่ 22 พฤศจิกายน พุทธศักราช 2544

ปัจจุบันมีการผลิตถุงปัสสาวะได้ภายในประเทศ ซึ่งมีการนำมาใช้ภายในประเทศและส่งไปจำหน่ายยังต่างประเทศ เพื่อสร้างความมั่นใจแก่ผู้ใช้และเพื่อส่งเสริมอุตสาหกรรมภายในประเทศ จึงกำหนดมาตรฐานผลิตภัณฑ์อุตสาหกรรม ถุงเก็บปัสสาวะ เล่ม 2 คุณลักษณะที่ต้องการและวิธีทดสอบ ขึ้น

มาตรฐานผลิตภัณฑ์อุตสาหกรรมนี้กำหนดขึ้นโดยรับ ISO 8669-2 : 1996 Urine collection bags - Part 2 : Requirements and test methods มาใช้ในระดับเหมือนกันทุกประการ (identical) โดยใช้ ISO 8669-2 : 1996 ฉบับภาษาอังกฤษเป็นหลัก

มาตรฐานผลิตภัณฑ์อุตสาหกรรมนี้กำหนดขึ้นเพื่อให้ทันกับความต้องการของผู้ใช้และจักได้แปลเป็นภาษาไทยในโอกาสอันสมควร หากมีข้อสงสัยโปรดติดต่อสอบถามสำนักงานมาตรฐานผลิตภัณฑ์อุตสาหกรรม

คณะกรรมการมาตรฐานผลิตภัณฑ์อุตสาหกรรมได้พิจารณามาตรฐานนี้แล้ว เห็นสมควรเสนอรัฐมนตรีประกาศตาม มาตรา 15 แห่งพระราชบัญญัติมาตรฐานผลิตภัณฑ์อุตสาหกรรม พ.ศ. 2511



ประกาศกระทรวงอุตสาหกรรม

ฉบับที่ 2923 (พ.ศ. 2544)

ออกตามความในพระราชบัญญัติมาตรฐานผลิตภัณฑ์อุตสาหกรรม

พ.ศ. 2511

เรื่อง กำหนดมาตรฐานผลิตภัณฑ์อุตสาหกรรม

ถุงเก็บปัสสาวะ เล่มที่ 2 คุณลักษณะที่ต้องการและวิธีทดสอบ

อาศัยอำนาจตามความในมาตรา 15 แห่งพระราชบัญญัติมาตรฐานผลิตภัณฑ์อุตสาหกรรม พ.ศ. 2511 รัฐมนตรีว่าการกระทรวงอุตสาหกรรมออกประกาศกำหนดมาตรฐานผลิตภัณฑ์อุตสาหกรรม ถุงเก็บปัสสาวะ เล่ม 2 คุณลักษณะที่ต้องการและวิธีทดสอบ มาตรฐานเลขที่ มอก.1806 เล่ม 2-2542 ไว้ ดังมีรายการละเอียดต่อท้ายประกาศนี้

ประกาศ ณ วันที่ 10 สิงหาคม พ.ศ. 2544

สุริยะ จึงรุ่งเรืองกิจ

รัฐมนตรีว่าการกระทรวงอุตสาหกรรม

มาตรฐานผลิตภัณฑ์อุตสาหกรรม

ถุงเก็บปัสสาวะ

เล่ม 2 คุณลักษณะที่ต้องการและวิธีทดสอบ

บทนำ

มาตรฐานผลิตภัณฑ์อุตสาหกรรมนี้กำหนดขึ้นโดยรับ ISO 8669-2:1996 Urine collection bags-Part 2 : Requirements and test method มาใช้ในระดับเหมือนกันทุกประการ (identical) โดยใช้ ISO ฉบับภาษาอังกฤษเป็นหลัก

ขอบข่าย

มาตรฐานผลิตภัณฑ์อุตสาหกรรมนี้กำหนดคุณลักษณะที่ต้องการด้านสมรรถนะในการใช้งานและวิธีทดสอบถุงเก็บปัสสาวะชนิดเปิดปลายได้ (open-ended) และชนิดเปิดปลายไม่ได้ (close-ended) ทั้งแบบที่สามารถผูกติดกับร่างกาย (body-worn bags) และแบบแขวนกับที่แขวนหรือเสาที่ตั้งกับพื้น โดยกำหนดนิยามของคำศัพท์ที่เกี่ยวข้อง คุณลักษณะที่ต้องการทางด้านสมรรถนะในการใช้งานได้แก่ ความไม่รั่วซึมเมื่อไม่มีภาระ ความไม่รั่วซึมเมื่อมีภาระ ความไม่รั่วซึมเมื่อมีแรงอัด (impact) คุณภาพของวาล์วกันการย้อนกลับ (ถ้ามี) ความแข็งแรงของระบบผูกแขวน (attachment system) ความแข็งแรงของจุดเชื่อมต่อของท่อทางเข้า (inlet tube) กับถุงเก็บปัสสาวะ ความดัน/เวลาที่ใช้ในการเริ่มไหลเข้าสู่ถุงเก็บปัสสาวะ และอัตราการเติมของเหลวเข้าสู่ถุงเก็บปัสสาวะ มิติ (ถ้ากำหนด) ภาวะทดสอบ วิธีทดสอบและการรายงานผลทดสอบ รายละเอียดให้เป็นไปตาม ISO 8669-2 : 1996

ทั้งนี้ไม่ครอบคลุมถุงเก็บปัสสาวะที่ต่อจากหน้าท้อง (Urostomy bags) Urimeter และถุงเก็บปัสสาวะที่ใช้เฉพาะกับเด็ก

Urine collection bags —

Part 2: Requirements and test methods

1 Scope

This part of ISO 8669 specifies performance requirements and test methods for open-ended and closed-ended urine collection bags of the following types:

- a) urine collection bags intended to be worn on the body (body-worn bags);
- b) urine collection bags intended to be used with a hanger or a floor stand (non-body-worn bags).

It does not apply to urostomy bags, urimeters and urine bags intended specifically for paediatric use.

2 Normative reference

The following standard contains provisions which, through reference in this text, constitute provisions of this part of ISO 8669. At the time of publication, the edition indicated was valid. All standards are subject to revision, and parties to agreements based on this part of ISO 8669 are encouraged to investigate the possibility of applying the most recent edition of the standard indicated below. Members of IEC and ISO maintain registers of currently valid International Standards.

ISO 8669-1:1988, *Urine collection bags — Part 1: Vocabulary*.

3 Definitions

For the purposes of this part of ISO 8669, the definitions given in ISO 8669-1 and the following definitions apply.

3.1 closed-ended urine collection bag: Flexible container for collecting urine, without an opening for drainage of the contents.

3.2 open-ended urine collection bag: Flexible container for collecting urine, with an opening for drainage of the contents.

3.3 rated volume: Capacity of the bag, expressed in millilitres, as stated by the manufacturer.

3.4 test volume: That volume on which is based the volume of liquid added, or the force applied, to a urine collection bag when performing tests to verify the strength and leakage resistance of the bag assembly (see 6.1).

4 Requirements

4.1 Rated volume

When measured by the method given in 6.1, the bag shall have a rated volume not larger than the test volume.

4.2 Freedom from leakage without load

When tested by the method given in 6.2, the bag shall not leak.

4.3 Freedom from leakage under load

When tested by the method given in 6.3, the bag shall not leak.

4.4 Freedom from leakage under impact

When tested by the method given in 6.4, the bag shall not leak.

4.5 Nonreturn valve

If a nonreturn valve is fitted, when tested by the method given in 6.5, the reflux flowrate shall not exceed 10 ml/min.

4.6 Strength of the attachment system

When the attachment system of bags provided with cutouts is tested by the method given in 6.6, none of the attachment points shall fail to support the bag.

When the attachment system of bags provided with a button and buttonhole system is tested by the method given in 6.7, none of the buttons and buttonholes shall fail to support the bag.

When bags provided with integral suspensory systems are tested by the method given in 6.8, no part of the integral suspensory system shall fail to support the bag.

4.7 Strength of attachment of the inlet tubing

When tested by the method given in 6.9, the inlet tubing shall not become detached from the bag.

4.8 Pressure/time required to initiate flow into the bag and filling rate

When tested by the method given in 6.10, the water shall start flowing into the bag within 1 min and the average filling rate shall be not less than 10 ml/s.

4.9 Dimensions

If dimensions are given, they shall be measured in accordance with annex A.

5 General test conditions

5.1 Temperature

The standard temperature for testing (atmosphere and reagent) shall be $23\text{ }^{\circ}\text{C} \pm 2\text{ }^{\circ}\text{C}$.

5.2 Test samples

Testing shall be carried out on product samples as supplied to the end user.

6 Test methods

6.1 Test volume

6.1.1 Principle

The urine collection bag is filled with water and the volume of water within the bag is measured.

6.1.2 Reagent

6.1.2.1 Tap water

6.1.3 Apparatus

6.1.3.1 **Graduated cylinders**, of capacities to suit the bags being tested and having a measurement accuracy of $\pm 2\%$.

6.1.3.2 **Filling system**, of arrangement and dimensions shown in figure 1.

To maintain a constant hydrostatic head, the rate of flow into the reservoir of the filling system shall be higher than the rate of the filling of the bag.

6.1.3.3 **Stopwatch**, or similar timing device.

6.1.4 Procedure

6.1.4.1 Cut the inlet tubing so that the reservoir tap is positioned as close as possible to the bag.

NOTE — For bags having extensible tubing, these should be drawn out to their maximum length before cutting.

6.1.4.2 Remove as much air as possible from the bag. Close the drainage tap afterwards.

NOTE — Most bags have a drainage tap through which air can be squeezed out.

6.1.4.3 Measure the distance between bottom and top of the bag (l_4 in figure A.1) and mark a horizontal line at $0,75 l_4$, measuring from the bottom of the bag.

6.1.4.4 Suspend a non-body-worn bag using the manufacturer's recommended suspension system. Suspend a body-worn bag freely in a vertical position, so that the volume of the bag is not restricted.

6.1.4.5 Using the filling system (6.1.3.2), ensure that the reservoir tap is closed, turn on the water supply (6.1.2.1) and adjust the hydrostatic head to $500 \text{ mm} \pm 5 \text{ mm}$. Connect the reservoir tap to the inlet tubing of the bag.

6.1.4.6 Open the reservoir tap and allow water to enter the bag, ensuring that no air is entrained.

6.1.4.7 When the water level inside the bag has risen to the $0,75 l_4$ line, start the stopwatch (6.1.3.3).

6.1.4.8 After 1 min but before 1 min 10 s, close the reservoir tap.

6.1.4.9 Visually inspect the bag to determine whether or not leakage has occurred. If leakage has occurred, deem the test invalid and repeat it, using a fresh bag if necessary.

6.1.4.10 Clamp the inlet tubing as close to the filling top surface of the bag as possible. Remove the bag from the filling system and empty the water from the bag into a graduated cylinder (6.1.3.1). Measure the volume, in millilitres, and record it as the test volume to an accuracy of $\pm 2\%$.

6.1.5 Test report

The test report shall contain the general information specified in clause 7, together with the test volume.

Dimensions in millimetres

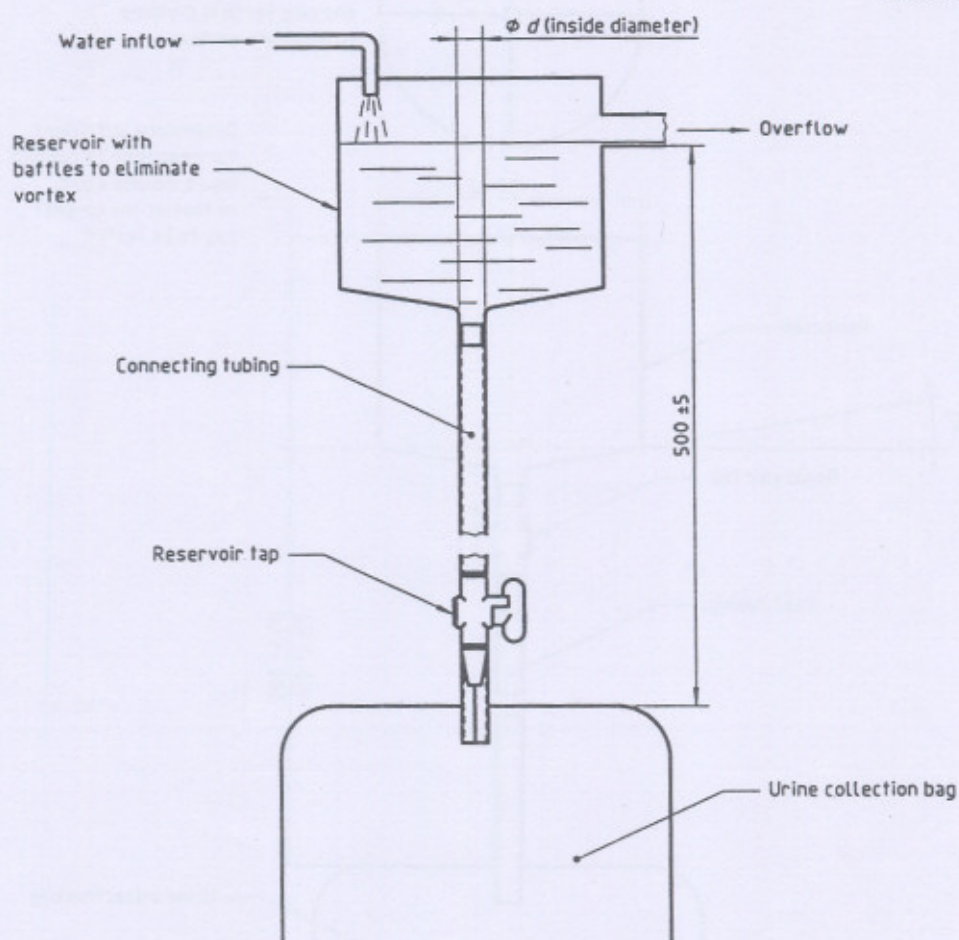

NOTE — $d \geq$ largest internal diameter of inlet tubing of bag.

Figure 1 — Filling system for determination of test volume

6.2 Freedom from leakage without load

6.2.1 Principle

The urine collection bag is filled with coloured water, positioned horizontally and examined for leakage. It is then suspended vertically and again inspected visually for leakage.

6.2.2 Reagents

6.2.2.1 Tap water

6.2.2.2 Coloured water, comprising tap water coloured by the addition of 0,3 g/l of erythrosin (E 127).

6.2.2.3 Absorbent material, white.

6.2.3 Apparatus

6.2.3.1 Graduated cylinder, as specified in 6.1.3.1.

6.2.3.2 Filling system, of arrangement and dimensions shown in figure 2.

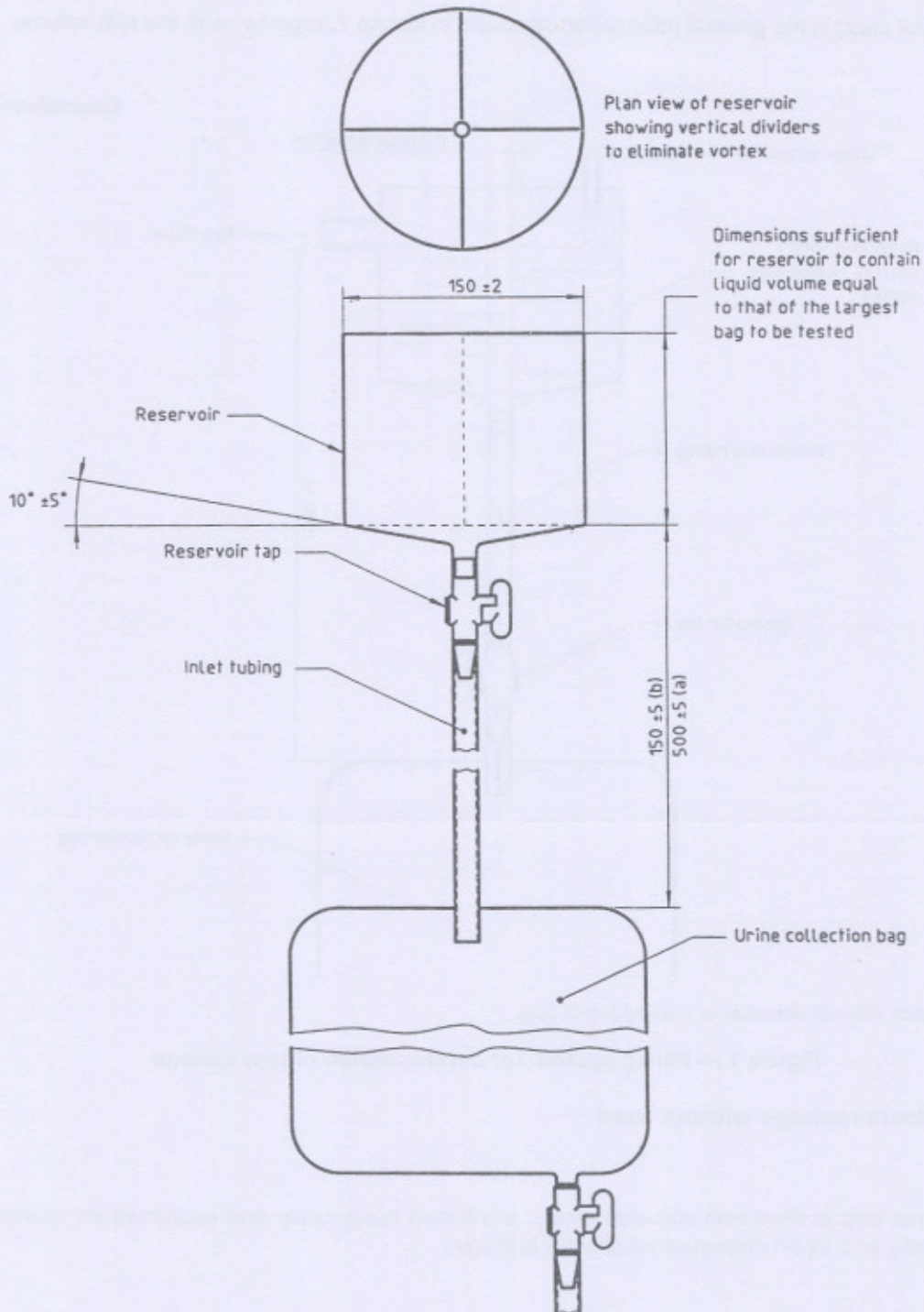

Figure 2 — Filling system for freedom of leakage test (a) and measurement of filling rate (b)

6.2.4 Procedure

6.2.4.1 Suspend a non-body-worn bag using the manufacturer's recommended suspension system. Suspend a body-worn bag freely, so that the volume of the bag is not restricted.

6.2.4.2 If the bag is fitted with a drainage tap, add a small volume of the water (6.2.2.1) into the bag, open the drainage tap and allow the bag to drain, and then fully open and close the drainage tap ten times. Empty the bag and close the tap.

6.2.4.3 Using the graduated cylinder and the filling system in figure 2 with a distance of $500 \text{ mm} \pm 5 \text{ mm}$ between the top of the bag and the bottom of the reservoir, add to the bag a volume of coloured water (6.2.2.2) equal to 75 % of the test volume (6.1.4.10), ensuring that no air is entrained.

6.2.4.4 Seal the inlet tubing and, if present, the air vent.

6.2.4.5 Place the absorbent material (6.2.2.3) on a flat surface. Remove the bag from the suspension system and place it horizontally on the absorbent material.

6.2.4.6 Leave the bag undisturbed for $17 \text{ h} \pm 1 \text{ h}$ and then visually inspect the bag and absorbent material for staining caused by leakage. If staining is observed, the urine collection bag under test is deemed to have failed.

6.2.4.7 Reposition the bag under test in a vertical position, as described in 6.2.4.1, above absorbent material.

6.2.4.8 Leave the bag undisturbed for $4 \text{ h} \pm 1 \text{ h}$, then visually inspect the bag and absorbent material for staining caused by leakage. If staining is observed, the urine collection bag under test is deemed to have failed.

6.2.5 Test report

The test report shall contain the general information specified in clause 7, together with a statement as to whether or not leakage was observed and, if so, from where the leakage occurred and at which orientation of the bag.

6.3 Freedom from leakage under load

6.3.1 Principle

Coloured water is added to the uring collection bag under test, which is then subjected to a compressive load between two parallel plates. The bag is then visually inspected for leakage.

6.3.2 Reagent

6.3.2.1 Coloured water, as specified in 6.2.2.2.

6.3.2.2 Absorbent material, white.

6.3.3 Apparatus

6.3.3.1 Graduated cylinder, as specified in 6.1.3.1.

6.3.3.2 Filling system, of arrangement and dimensions shown in figure 2.

6.3.3.3 Flat, rigid plate, of length and width not less than those of the bag being tested.

6.3.3.4 Restraints, capable of allowing the plate to move freely in a vertical direction whilst remaining horizontal within a tolerance of $\pm 5^\circ$.

6.3.3.5 Weights, or other means of loading the plate, to produce total downward force of $200 \text{ N} \pm 10 \text{ N}$ on the bag.

6.3.3.6 Stopwatch, or similar timing device.

6.3.4 Procedure

6.3.4.1 Add coloured water (6.3.2.1) to the bag, as specified in 6.2.4.3.

6.3.4.2 Seal the inlet tubing and, if present, the air vent.

6.3.4.3 Place the absorbent material (6.3.2.2) on a horizontal, flat rigid surface. Place the bag horizontally on the absorbent material.

6.3.4.4 Place the flat, rigid plate (6.3.3.3) on the top of the bag, position the restraints (6.3.3.4) and load the plate gently with the weights (6.3.3.5) so that a total force of $200\text{ N} \pm 10\text{ N}$ is imposed on the bag.

6.3.4.5 Allow the force to act on the bag at least 1 min but not longer than 1 min 10 s. Remove the force and visually inspect the bag and the white absorbent material for staining caused by leakage. If staining is observed, the urine collection bag under test is deemed to have failed.

6.3.5 Test report

The test report shall contain the general information specified in clause 7, together with a statement as to whether leakage was observed, and if so, from where.

6.4 Freedom from leakage under impact

6.4.1 Principle

Water is added to the urine collection bag, which is then dropped on to a smooth, rigid surface. The bag is then visually inspected for leakage.

6.4.2 Reagent

6.4.2.1 Tap water.

6.4.3 Apparatus

6.4.3.1 Graduated cylinder, as specified in 6.1.3.1.

6.4.3.2 Filling system, of arrangement and dimensions shown in figure 2.

6.4.3.3 Smooth, rigid surface, for instance a ceramic floor or a heavy steel plate.

6.4.4 Procedure

6.4.4.1 Using the graduated cylinder (6.4.3.1) and the filling system in figure 2 with a distance of $500\text{ mm} \pm 5\text{ mm}$ between the top of the bag and the bottom of the reservoir, add to the bag a volume of water (6.4.2.1) equal to 50 % of the test volume (see 6.1.4.10), ensuring that no air is entrained.

6.4.4.2 Seal the inlet tubing and, if present, the air vent.

6.4.4.3 Hold the bag so that the lowest edge is a distance of $500\text{ mm} \pm 10\text{ mm}$ above the smooth, rigid surface (6.4.3.3), and then drop the bag so that it strikes the surface with the bottom of the bag.

6.4.4.4 Visually inspect the bag for leakage.

6.4.4.5 Repeat 6.4.4.1 to 6.4.4.4 twice more, using a fresh bag each time, dropping them so that one

a) strikes the surface with one face of the bag

and the other

b) strikes the surface with one side edge of the bag.

6.4.5 Test report

The test report shall contain the general information specified in clause 7, together with a statement as to whether leakage was observed on any bag, and if so, which drop attitude caused the damage and where the leakage occurred.

6.5 Nonreturn valve

6.5.1 Principle

Water is added to the urine collection bag, which is then subjected to a compressive load, and the reflux through the nonreturn valve is measured.

6.5.2 Reagent

6.5.2.1 Tap water.

6.5.3 Apparatus

6.5.3.1 Graduated cylinders, of capacities to suit the bags being tested and the volume passing the nonreturn valve, and having a measurement accuracy of $\pm 2\%$.

6.5.3.2 Flat, rigid plate, of length and width not less than those of the bag being tested.

6.5.3.3 Restraints, capable of allowing the plate to move freely in a vertical direction whilst remaining horizontal within a tolerance of $\pm 5^\circ$.

6.5.3.4 Weights, or other means of loading the plate to produce a total downwards force of $100\text{ N} \pm 5\text{ N}$ on the bag.

6.5.3.5 Stopwatch, or similar timing device.

6.5.4 Procedure

6.5.4.1 If the inlet tubing of the bag is longer than 50 mm, cut it to a length of $50\text{ mm} \pm 10\text{ mm}$.

For bags having extensible tubing, the tubes shall be drawn out to maximum length before cutting.

Some bags incorporate the nonreturn valve in the inlet tubing. Ensure that such a valve is not compromised or damaged when cutting.

6.5.4.2 Add water to the bag as specified in 6.4.4.1.

6.5.4.3 Place the bag on a flat, rigid and horizontal surface, with the inlet tubing draining over the edge of this surface.

6.5.4.4 Place the flat, rigid plate (6.5.3.2) on the top of the bag, position the restraints (6.5.3.3) and load the plate gently with the weights (6.5.3.4) so that a total force of $100\text{ N} \pm 5\text{ N}$ is imposed on the bag.

6.5.4.5 Allow the force to act on the bag for at least 5 min but no longer than 5 min 10 s. Using the graduated cylinders (6.5.3.1), collect and measure the quantity of water that emerges from the inlet tubing during that time to an accuracy of $\pm 2\text{ ml}$, ignoring any flow occurring before the force is imposed. Calculate the rate of leakage past the nonreturn valve in millilitres per minute.

6.5.5 Test report

The test report shall contain the general information specified in clause 7, together with the rate of leakage past the nonreturn valve, expressed in millilitres per minute.

6.6 Strength of the attachment system of bags provided with cutouts

6.6.1 Principle

The urine collection is suspended on a rod passed through the cutouts and a weight is attached to the bottom of the bag. The bag is then visually inspected for damage.

6.6.2 Apparatus

6.6.2.1 Rigid rod of $6 \text{ mm} \pm 0,1 \text{ mm}$ diameter, with a means to support it in a horizontal attitude.

6.6.2.2 Suitable clamp, which will grip across the full width of the bottom of the bag, having means by which a weight can be attached.

6.6.2.3 Selection of weights, each having a means of attachment to the clamp the combined mass of the weights and clamp being equal to 1,5 times the mass of the test volume of the bag to be tested.

6.6.3 Procedure

6.6.3.1 Pass the rod (6.6.2.1) through the minimum number of attachment cutouts in the top of the bag, as shown in figure 3, following the manufacturer's instructions.

6.6.3.2 Mount the rod in a horizontal attitude so that the bag hangs freely on the rod.

6.6.3.3 Attach the clamp (6.6.2.2) to the bottom of the bag as shown in figure 3. If the bag has an outlet device at the bottom which interferes with the fitting of the clamp, cut off the outlet device so that a smooth area of the bag is available to accept the clamp.

6.6.3.4 Attach the appropriate weight (6.6.2.3) to the clamp so that the combined mass of the weight and the clamp is equal to 1,5 times the mass of the test volume (see 6.1.4.10) of the bag.

6.6.3.5 Allow the force to act on the bag for $24 \text{ h} \pm 1 \text{ h}$. Visually inspect the attachment cutouts.

Dimensions in millimetres

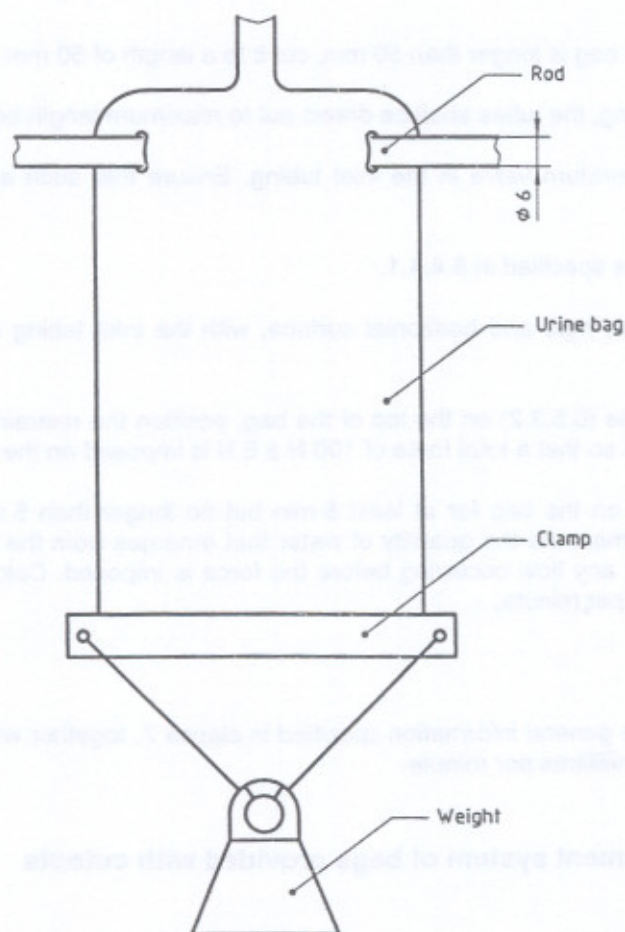

Figure 3 — Schematic of test for strength of attachment system of bags provided with cutouts

6.6.4 Test report

The test report shall contain the general information specified in clause 7, together with a statement as to whether any of the attachment cutouts has broken through to the outside of the bag.

6.7 Strength of the attachment system of bags provided with a button and buttonhole system

6.7.1 Principle

The urine collection bag is suspended, buttoned to test pieces of strap, and a weight is attached to the bottom of the bag. The bag is then visually inspected for damage.

6.7.2 Apparatus

6.7.2.1 Two lengths of strap, of the same type as that supplied with the bag to be tested, with attachment means at one end of each piece, and a means for attaching the straps to a fixed, horizontal surface.

6.7.2.2 Suitable clamp, as specified in 6.6.2.2.

6.7.2.3 Selection of weights, as specified in 6.6.2.3.

6.7.3 Procedure

6.7.3.1 Mount the two lengths of strap (6.7.2.1) to a fixed horizontal support so that a line drawn between the attachment points is horizontal and the distance between them is the same as that of the attachment points of the bag being tested.

6.7.3.2 Attach the bag to the straps by the button and buttonholes, as shown in figure 4.

6.7.3.3 Attach the clamp (6.7.2.2) as specified in 6.6.3.3.

6.7.3.4 Attach the appropriate weight (6.7.2.3) as specified in 6.6.3.4.

6.7.3.5 Allow the force to act on the bag for $24\text{ h} \pm 1\text{ h}$. Visually inspect the condition of the buttons and buttonholes.

6.7.4 Test report

The test report shall contain the general information specified in clause 7 together with a statement as to whether any of the buttons or buttonholes has failed to support the bag.

6.8 Strength of integral suspensory systems

6.8.1 Principle

The urine collection bag is suspended by means of its integral system and a weight is attached to the bottom of the bag. The bag system is then visually inspected for damage.

6.8.2 Apparatus

6.8.2.1 Suitable support, which will allow the bag to be suspended according to the manufacturer's instructions.

6.8.2.2 Suitable clamp, as specified in 6.6.2.2.

6.8.2.3 Selection of weights, as specified in 6.6.2.3.

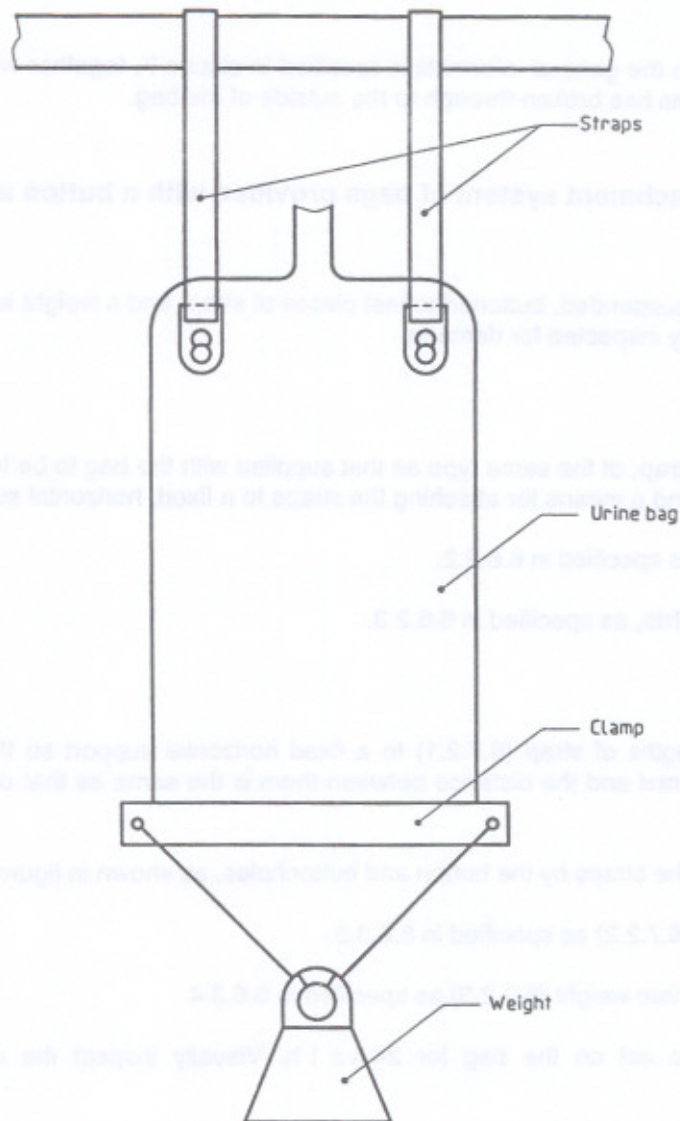

Figure 4 — Schematic of test for strength of attachment system of bags provided with buttons and buttonholes

6.8.3 Procedure

6.8.3.1 Suspend the bag by means of its integral suspensory system to a suitable support (6.8.2.1), following the manufacturer's instructions.

6.8.3.2 Attach the clamp (6.8.2.2) as specified in 6.6.3.3.

6.8.3.3 Attach the appropriate weight (6.8.2.3) as specified in 6.6.3.4.

6.8.3.4 Allow the force to act on the bag for $24 \text{ h} \pm 1 \text{ h}$. Visually inspect the system.

6.8.4 Test report

The test report shall contain the general information specified in clause 7, together with a statement as to whether any part of the integral suspensory system has failed to support the bag.

6.9 Strength of attachment of the inlet tubing

6.9.1 Principle

A tensile force is applied between the urine collection bag and the inlet tubing in an attempt to separate the component from the bag.

6.9.2 Apparatus

6.9.2.1 **Clamp**, or similar device, for suspending the bag.

6.9.2.2 **Weight**, with a means of attaching it to the inlet tubing, having a total mass to exert a gravitational force equal to $40 \text{ N} \pm 1 \text{ N}$.

6.9.2.3 **Stopwatch**, or similar timing device.

6.9.3 Procedure

6.9.3.1 Suspend the bag, using the clamp (6.9.2.1), with the inlet tubing downwards.

6.9.3.2 Attach the weight (6.9.2.2) to the lower end of the inlet tubing.

6.9.3.3 Lower the weight without imposing a shockload until it is freely suspended and allow it to hang unsupported for at least 1 min but no longer than 1 min 10 s as measured with the timing device (6.9.2.3).

6.9.3.4 Visually inspect the connection of the inlet tubing to the bag.

6.9.4 Test report

The test report shall contain the general information specified in clause 7, together with a statement as to whether the inlet tubing has become detached from the bag.

6.10 Pressure/time required to initiate flow into the bag and filling rate

6.10.1 Principle

A hydrostatic head is applied to the urine collection bag to verify that water will enter the bag and, if so, the time for 50 % of the test volume of water to enter the bag is measured and the average filling rate is calculated.

6.10.2 Reagent

6.10.2.1 **Tap water**.

6.10.3 Apparatus

6.10.3.1 **Graduated cylinders**, as specified in 6.1.3.1.

6.10.3.2 **Filling system**, of arrangement and dimensions shown in figure 2.

6.10.3.3 **Stopwatch**, or similar timing device.

6.10.4 Procedure

6.10.4.1 Remove as much air as possible from the bag. Close the drainage tap afterwards.

NOTE — Most bags have a drainage tap through which air can be squeezed out.

6.10.4.2 Suspend a non-body-worn bag by the manufacturer's recommended suspension system. Suspend a body-worn bag freely so that the volume of the bag is not restricted.

6.10.4.3 Ensure that the reservoir tap is closed. Add to the reservoir, by means of a graduated cylinder, a volume of water (6.10.2.1) equal to 50 % of the test volume (see 6.1.4.10) and adjust the reservoir so that bottom is 150 mm \pm 5 mm above the top of the tap. Connect the reservoir tap to the inlet tubing or, if fitted, to the connector of the inlet tubing.

NOTES

1 If an extra length of tubing is required to make the connection, use tubing of internal diameter no less than that of the inlet tubing of the bag.

2 There should be no restriction to flow into the bag from twisting or sharp bending of the inlet tubing. Inlet tubings longer than 150 mm should be adequately supported to avoid air pockets in the inlet tubing.

6.10.4.4 Open the tap on the reservoir and, using the stopwatch (6.10.3.3), measure the time, in seconds, taken for the total quantity of water to enter the bag. Start the timing device when the tap is opened, and stop it when the flow of water becomes discontinuous or, if no water has entered the bag, between 1 min and 1 min 10 s.

6.10.4.5 Visually inspect the bag to determine whether or not leakage has occurred. If leakage has occurred, deem the test invalid and repeat it, using a fresh bag if necessary.

6.10.4.6 Calculate the average filling rate, in millilitres per second.

6.10.5 Test report

The test report shall contain the general information specified in clause 7, together with a statement as to whether any water has flowed into the bag within 1 min to 1 min 10 s, and if so, the average filling rate, expressed in millilitres per second.

7 Test reports

The test reports shall include the following information:

- a) reference to this part of ISO 8669;
- b) complete identification of the bag tested;
- c) date and place of testing;
- d) number of bags tested;
- e) test results as specified in 6.1.5, 6.2.5, 6.3.5, 6.4.5, 6.5.5, 6.6.4, 6.7.4, 6.8.4, 6.9.4 and 6.10.5.

Annex A (normative)

Dimensions of urine collection bags

This annex specifies the method for determining the dimensions of urine collection bags. Its purpose is to indicate dimensions related to the end use of the bag.

Dimensions identified by this method are for identification purposes only, and do not individually or collectively define or recommend a product of a specific design, style or size.

A.1 Principle

The empty bag is laid on a flat surface and specified dimensions are recorded (see figure A.1).

A.2 Apparatus

A.2.1 Measuring instruments, capable of measuring in increments of 0,5 mm.

A.3 Procedure

A.3.1 Lay the empty bag on a flat, horizontal surface. If the bag has a drainage tap, set it in the closed position according to the manufacturer's instructions.

A.3.2 Measure the inside diameter of the connector, if present, to the nearest 0,5 mm (dimension d_1 in figure A.1).

A.3.3 Determine where the smallest inside diameter exists in the inlet fluid pathway, which includes inlet tubing, connector, drip chamber, air vent and sampling site. Measure this internal diameter to the nearest 0,5 mm (dimension d_2 in figure A.1).

A.3.4 Measure the distance from the end of the tubing or, if present, the tip of the connector to the lowest part of the urine bag assembly, to the nearest 10 mm (dimension l_1 in figure A.1).

A.3.5 Measure the length of the inlet tubing from the end of the tubing or, if present, the tip of the connector to the top of the urine bag, to the nearest 10 mm (dimension l_2 in figure A.1).

A.3.6 Measure the distance between the geometric centres of the attachment points, to the nearest 1 mm (dimension l_3 in figure A.1).

A.3.7 Measure the distance from the top to the bottom of the bag, excluding inlet and outlet tubing and drainage tap, to the nearest 1 mm (dimension l_4 in figure A.1).

A.3.8 Measure the length of the outlet tubing/drainage tap from the bottom of the bag to the lowest part of the urine bag assembly, to the nearest 1 mm (dimension l_5 in figure A.1).

A.4 Test report

The test report shall contain the general information specified in clause 7, together with the measurements described in A.3.

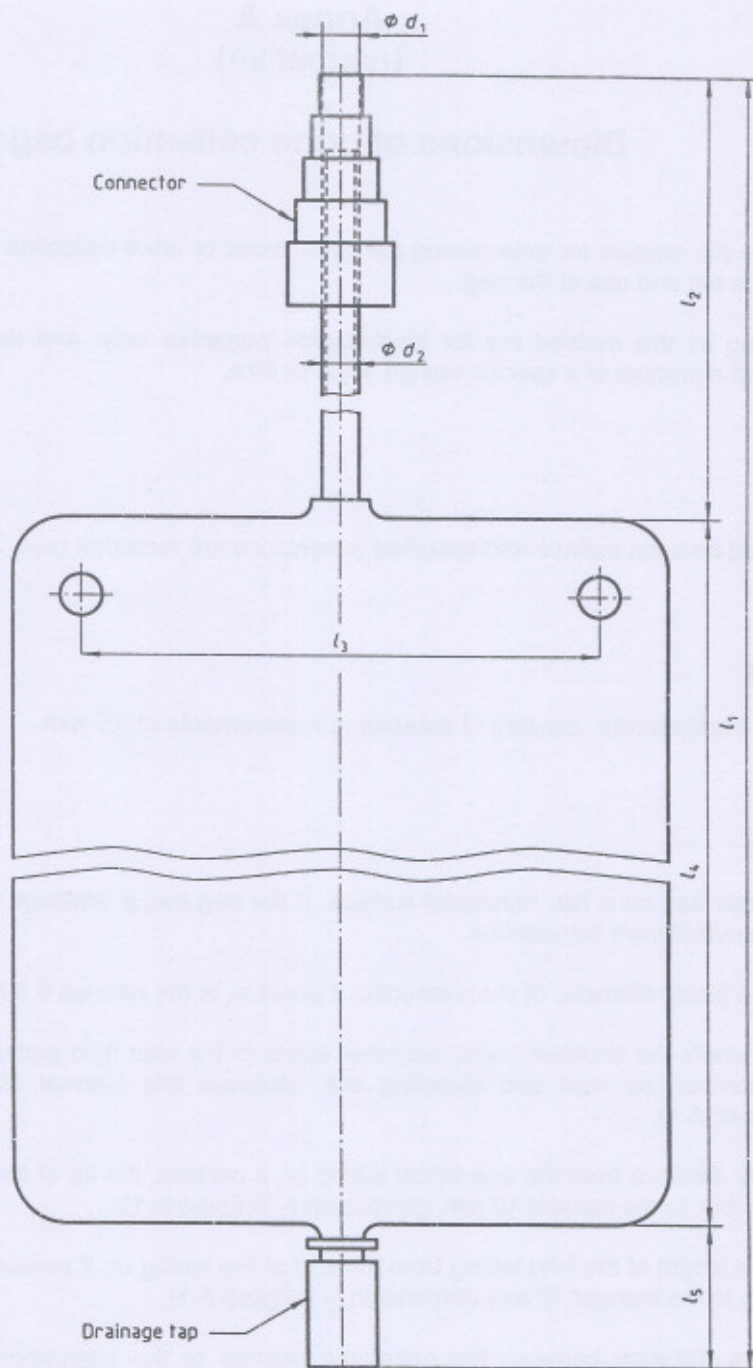

Figure A.1 — Typical dimensions of a urine collection bag